

## LMD Coolant Ring Installation Guide

### Version 1.00

1. Remove coolant ring from packing.
2. For 770 m/m+/mx/ series 3 along with 1100 use the left most slot on the coolant ring. Slide the bolt up through the slot as shown in Fig A and Fig B.
3. On the underside of the spindle casting housing there will be two threaded holes. One smaller and one larger, this bolts into the larger of the 2 holes (M6 threaded hole).
4. Screw Bolt in until hand tight using an allen key

**Fig A.**

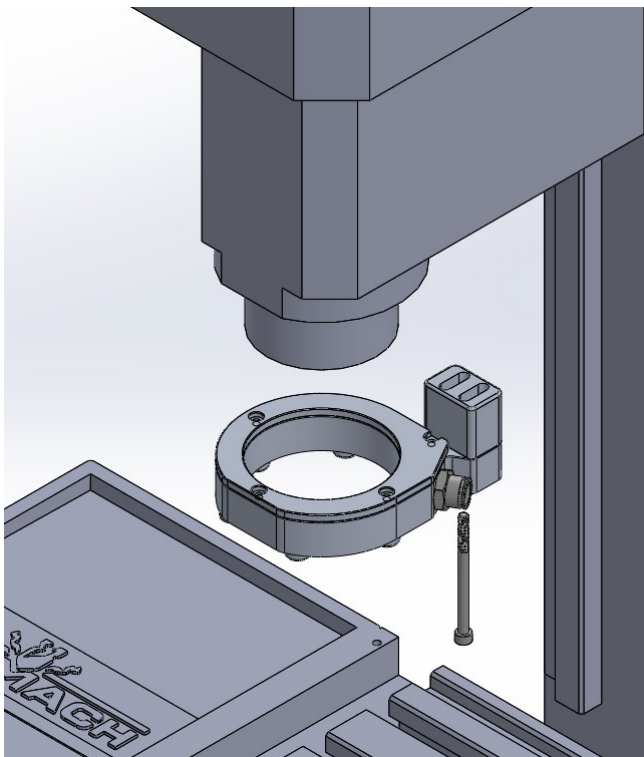

**Fig B.**

